

# MONOLITHIC AMPLIFIERS 50 & 75Ω

Surface Mount

High IP3 5 to 1000 MHz

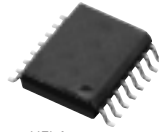

HELA

All specifications at 25°C

KIT NO.	APPLICATION CIRCUIT	FREQ. (MHz) f <sub>i</sub> - f <sub>u</sub>	OHMS	GAIN <sup>1</sup> (dB)			Typ. Flatness	MAXIMUM POWER (dBm)			DYNAMIC RANGE		VSWR <sup>2</sup> (:1) Typ.		DC POWER		THERMAL RESISTANCE <sup>3</sup> θ <sub>jc</sub> °C/W	CASE STYLE Note B	CONNECTION	PRICE \$ Qty. (1-9)
				Min.	Typ.	Max.		Output (1 dB Comp.) Typ.	Input (no damage) Min.	NF (dB) Typ.	IP3 (dBm) Typ.	In	Out	Volt Typ.	Current (mA)					
HELA-10A	A	50 - 1000	75	10	12	13	±0.4	30	26	20	3.5	47	1.22	1.22	12	525	6	CM624	kl	19.95
HELA-10B	B	50 - 1000	50	10★	12	13	±0.4	30	26	20	3.5	47	1.22	1.22	12	525	6	CM624	kl	19.95
HELA-10C	C	5 - 450	75	9.3	11.4	12.5	±0.4	30	26	20	3.5	48	1.3	1.22	12	525	6	CM624	kl	19.95
HELA-10D	D	8 - 300	50	9.3	11.0	12.5	±0.4	30	26	20	3.5	48	1.2	1.2	12	525	6	CM624	kl	19.95

◆ Kit consists of HELA-10 plus transformers, see table below.

### features

- very high IP3, 49 dBm typ at 150 MHz & 45 dBm typ at 800 MHz
- excellent flatness, ±0.4 dB typ.
- very high IP2, 88 dBm typ.
- low noise figure, 3.5 dB typ.

### applications

- cellular
- instrumentation
- CATV

### absolute maximum ratings

heat slug temperature: 110°C max.  
storage temperature: -40°C to 150°C  
dc voltage: 13V  
dc power: 7.15W

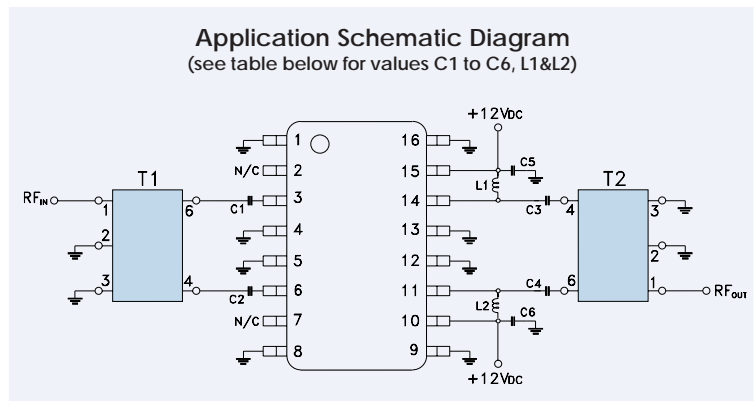

APPLICATION CIRCUIT	T1	T2	C1 TO C6	L1,L2	PCB LAYOUT	EVALUATION BOARD
A	ADTL1-18-75	ADTL1-18-75	0.01µF	0.75µH	B14-TB-30	TB-16
B	ADTL1-12	ADTL1-12	0.01µF	0.75µH	B14-TB-17	TB-17
C	ADT1-1WT	ADTL1-4-75	0.039µF	3.3µH	B14-TB-16	TB-30
D	ADT1.5-1	ADT1.5-1	0.039µF	3.3µH	B14-TB-17	TB-45

### Assembly Guideline

Reflow solder the slug to the ground plane; PC board layouts for 75 ohm (B14-TB-16), (B14-TB-30) and for 50 ohm (B14-TB-17) are available upon request. Please contact Applications Department or consult our website.

### NOTES:

- ◆ Aqueous washable
- † Open load is not recommended, potentially can cause damage. With no load, derate max input power by 20 dB.
- ★ 9.5 dB min., 800-1000 MHz.
- ⊛ Tested with recommended application schematic diagram.
- A. Environmental specifications and re-flow soldering information available in General Information Section.
- B. Units are non-hermetic unless otherwise noted. For details on case dimensions & finishes see "Case Styles & Outline Drawings".
- C. Prices and Specifications subject to change without notice.
- D. For Quality Control Procedures see Table of Contents, Section 0, "Mini-Circuits Guarantees Quality" article. For Environmental Specifications see Amplifier Selection Guide.
- 1. Includes transformer losses at input & output.
- 2. For 75 ohm. For 50 ohm, VSWR increases from 1.2:1 at 1 GHz to 2.0:1 at 500 MHz.
- 3. Thermal resistance is from junction to heat slug.

### pin connections

PORT	kl
RF IN	3,6
RF OUT	11,14
DC	10,15
GND EXT.	1,4,5,8,9,12,13,16
NOT USED	2,7

000602



The Design Engineers Search Engine  
Provides Actual Data Instantly  
At: <http://www.minicircuits.com>

In Stock... Immediate Delivery  
For Custom Versions Of Standard Models  
Consult Our Applications Dept.

